

It is recommended that a rebuild kit be used rather than a seal kit.
Insufficient lubrication, twisting of seals, etc, can adversely affect performance.

Rebuild Kit Contents

Handle	Handle Set Screw	Plug
O-Rings (3)	Snap Ring	

NOTE: Brass plugs have green PTFE coating,
316 SS plugs have gray PTFE coating

Seal Kit Contents

O-Rings (3) 2 Sizes

WARNING
If the valve is disconnected from
a system for installation, it must be
depressurized, cycled, and purged.

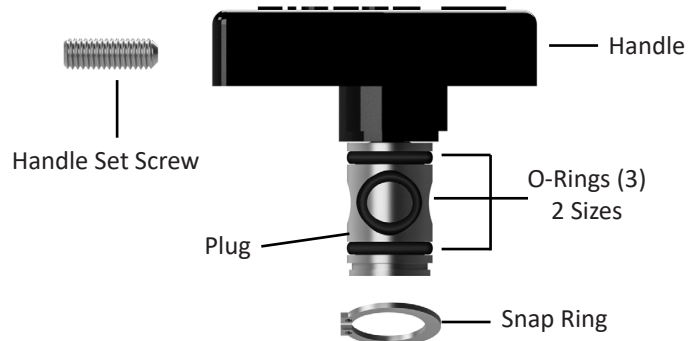

Figure 1

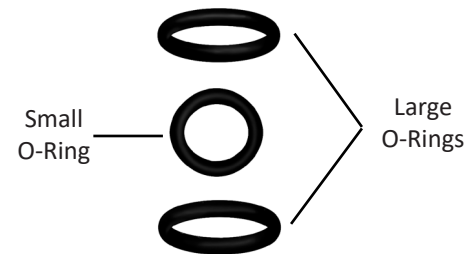

Figure 2

Rebuild Kit Instructions

1. Remove snap ring using snap ring pliers or similar tool, and discard. See Figure 4. Turn handle to the open position
2. Lift up handle to remove old plug and discard entire subassembly
3. Clean body bore and lubricate lightly with a silicone-based lubricant
4. Remove protective sleeve from new plug. Insert plug straight down into body. See Figure 3

NOTE: Do not pinch O-Rings
between body and plug

5. Install snap ring with snap ring pliers or similar tool. See Figure 4
6. Verify handle set screw is tight, tighten as necessary
7. Test the valve for proper operation

Seal Kit Instructions

1. Remove snap ring using snap ring pliers or similar tool. See Figure 4. Set aside. Turn handle to the open position
 2. Lift up handle to remove plug, remove the O-Rings from the plug, and discard O-Rings. See Figure 3
 3. Clean body bore and lubricate lightly with a silicone-based lubricant. Also lubricate entire surface of new O-Rings with a silicone-based lubricant. Install O-Rings on plug, with the larger two around the top and bottom of the plug, and the smaller one on the side.
 4. Insert plug straight down into body. See Figure 3
- NOTE:** Do not pinch O-Rings between body and plug
5. Install snap ring with snap ring pliers or similar tool. See Figure 4
 6. Verify handle set screw is tight, tighten as necessary
 7. Test the valve for proper operation

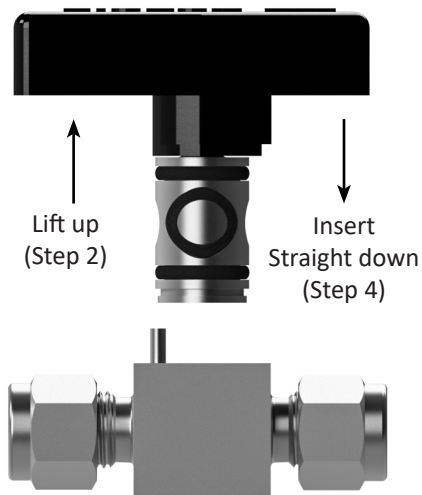

Figure 3

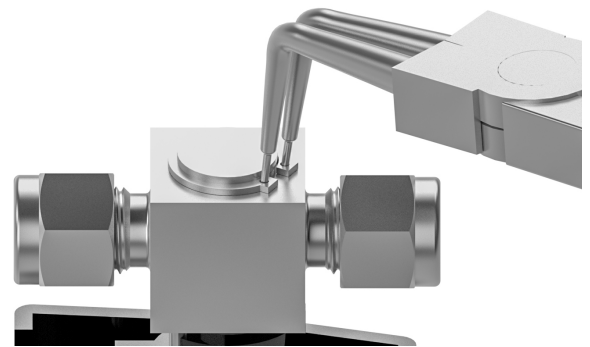

Figure 4