

Unilok[®] Tube Fittings



SSP
Instrumentation
A DIVISION OF SSP FITTINGS CORP.

www.sspfittings.com

**QUALITY
INSTRUMENTATION
FITTINGS**



Made in USA



SSP Fittings Corp. / SSP Instrumentation

Table of Contents

How to Order	3
Tube Fittings	
Selection Guide	4-6
Unilok Tube Fittings	
General Information	7-8
Interchangeability	8
Installation Instructions	9
Presetting Tool	10
Gageability	10
Tube Fittings	11-47
Components	48-49
Selection Guide for Instrument	
Fittings & Tubing	50-53
Safety Information	54
Warranty	54

SSP Instrumentation

It takes a team of experts working together to become a recognized leader in the instrumentation tube fitting marketplace. SSP Instrumentation combines the finest in manufacturing equipment and expertise with state-of-the-art design engineering, outstanding quality assurance, superior customer service, and an efficient inventory distribution system to accomplish the task.

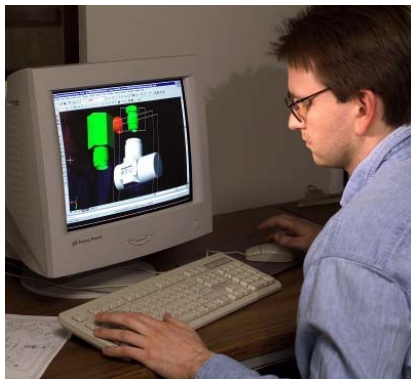

SSP Fittings Corp.

Since its inception in 1926, SSP has developed into an internationally recognized manufacturer of the highest quality, machined products. This successful U.S. corporation's heritage of craftsmanship and business expertise provide the foundation for an instrumentation division specializing in providing alternatives in instrumentation quality tube fittings.



Unilok® is a registered trademark of SSP Fittings Corp.
Monel® is a registered trademark of Inco Alloys International
Teflon® & Viton® are registered trademarks of E.I. duPont de Nemours
Hastelloy® is a registered trademark of Haynes International Inc.
Swagelok® is a registered trademark of the Swagelok Co.
Tygon® is a registered trademark of Norton Performance Plastics Corp.

NOTICE: This publication is an uncontrolled copy of a controlled document. SSP Instrumentation has made every reasonable effort to insure the accuracy of the information contained in this publication, and is not to be held liable in any manner for any mistakes, omissions, typographical and/or printing errors.

How to Order Unilok Tube Fittings

Example: ISSU4MC2

ISS	U	4	MC	2
------------	----------	----------	-----------	----------

Instrumentation Material Designator (See Chart #1)

SSP Brand Designator U = Unilok

Tube O.D. (See Chart #2)

Type of Tube Fitting (See Chart #3)

2nd end connection is required for a reduced size tube O.D. or a differing type of end connection such as MNPT, FNPT, etc. (See Chart #2)

For special application tees, a 3rd end connection is required for a reduced size tube O.D. or a differing type of end connection such as MNPT, FNPT, etc. (See Chart #2)

NOTES:

All Configurations: Only one size indicator is necessary when all of the connections are the same type and size.

Straights and Elbows: Specify the largest tube end first followed by the smaller tube end or differing type of connection (MNPT, FNPT, etc.).

Tees and Crosses: Tees are described by first sizing the run (1 to 2) and then the branch (3). Crosses are described by first sizing the run (1 to 2) and then the branch (3 to 4). See Figure 1.

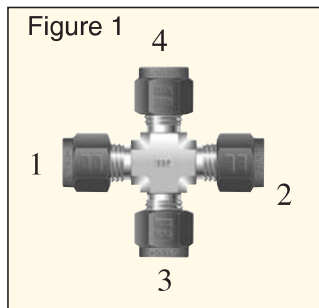

Specials: SSP Instrumentation manufactures a wide variety of special application tube fittings. Contact your local distributor for details regarding availability of special tube fitting configurations, materials and sizes.

CHART #1	
Instrumentation Material Designator	Material
IB	Brass
ISS	316 Stainless Steel
ICS	Carbon Steel
IHC	Hastelloy® C
IM	Monel®
IN*	Nylon
IPFA*	PFA Teflon®
ITFE*	PTFE Teflon®

* Ferrules Only











CHART #2 Part # Size Designators	
Size Designator	Tube O.D. or MNPT, FNPT Size*
1	1/16"
2	1/8"
3	3/16"
4	1/4"
5	5/16"
6	3/8"
8	1/2"
10	5/8"
12	3/4"
16	1"

* Tube O.D. expressed in sixteenths of an inch







CHART #3	
Type of Tube Fitting	Description of Unilok Tube Fitting Types
ANA	AN Adapter
ANBU	AN Bulkhead Union
ANF	Female AN Adapter
ANU	AN Union
BFC	Bulkhead Female Connector
BMC	Bulkhead Male Connector
BR	Bulkhead Reducer/Adapter
BRU	Bulkhead Reducing Union
BU	Bulkhead Union
CP	Cap
CU	Calibration Union
DA	Dielectric Adapter
DU	Dielectric Union
FA	Female Adapter
FBT	Female Branch Tee
FC	Female Connector
FCRT	Female Connector to ISO Tapered
FE	Female Elbow
FRT	Female Run Tee
HBA	Hose Barb Adapter
MA	Male Adapter
MAST	Male Adapter to Straight Thread Boss
MBT	Male Branch Tee
MBTST	Male Branch Tee to Straight Thread Boss
MC	Male Connector
MCBT	Male Connector Bored Through
MCRS	Male Connector to ISO Parallel
MCRT	Male Connector to ISO Tapered
MCST	Male Connector to Straight Thread Boss
ME	Male Elbow
MERT	Male Elbow to ISO Tapered
MEST	Male Elbow to Straight Thread Boss
M45E	Male 45° Elbow
M45EST	Male 45° Elbow to Straight Thread Boss
MPWC	Male Pipe Weld Connector
MPWE	Male Pipe Weld Elbow
MRT	Male Run Tee
MRTST	Male Run Tee to Straight Thread Boss
OMC	O-Ring Seal Male Pipe Connector
OSC	O-Ring Seal Straight Thread Connector
P	Plug
PC	Port Connector
R	Reducer/Adapter
RPC	Reducing Port Connector
RU	Reducing Union
TSWE	Tube Socket Weld Elbow
TSWU	Tube Socket Weld Union
U	Union
UCS	Union Cross
UE	Union Elbow
UT	Union Tee
COMPONENTS	
BN	Bulkhead Nut
KN	Knurled Nut
N	Nut
TI	Tube Insert

Unilok Tube Fittings Selection Guide

Tube to Male Pipe

<p>Male Connector</p>  <p>MC 11</p>	<p>Male Connector to ISO Parallel</p>  <p>MCRS 12</p>
<p>Male Connector to ISO Tapered</p>  <p>MCRT 13</p>	<p>Male Connector Bored Through</p>  <p>MCBT 14</p>
<p>Bulkhead Male Connector</p>  <p>BMC 15</p>	<p>Male Adapter</p>  <p>MA 34</p>
<p>Male Elbow</p>  <p>ME 16</p>	<p>Male Elbow to ISO Tapered</p>  <p>MERT 17</p>
<p>45° Male Elbow</p>  <p>M45E 15</p>	<p>Male Branch Tee</p>  <p>MBT 18</p>
<p>Male Run Tee</p>  <p>MRT 18</p>	









Tube to Female Pipe

<p>Female Connector</p>  <p>FC 19</p>	<p>Bulkhead Female Connector</p>  <p>BFC 20</p>
<p>Female Adapter</p>  <p>FA 35</p>	<p>Female Elbow</p>  <p>FE 22</p>
<p>Female Branch Tee</p>  <p>FBT 23</p>	<p>Female Run Tee</p>  <p>FRT 21</p>









Our selection guide makes it easy to locate any fitting. Simply turn to the page designated in the lower right hand corner.

Unilok Tube Fittings Selection Guide





Tube to Tube Union

<p>Union</p>  <p>U 23</p>	<p>Bulkhead Union</p>  <p>BU/BRU 24</p>
<p>Reducing Union</p>  <p>RU 25</p>	<p>Union Elbow</p>  <p>UE 26</p>
<p>Union Tee</p>  <p>UT 27</p>	<p>Reducing Union Tee</p>  <p>RUT 28</p>
<p>Union Cross</p>  <p>UCS 26</p>	<p>Dielectric Adapter / Union</p>  <p>DA/DU 29</p>

Tube Stub Connectors / Adapters



<p>Reducer/Adapter</p>  <p>R 33</p>	<p>Bulkhead Reducer/Adapter</p>  <p>BR 32</p>
<p>Port Connector</p>  <p>PC 36</p>	<p>Reducing Port Connector</p>  <p>RPC 36</p>
<p>Male Adapter</p>  <p>MA 34</p>	<p>Female Adapter</p>  <p>FA 35</p>
<p>Calibration Union</p>  <p>CU 38</p>	<p>Hose Barb Adapter</p>  <p>HBA 37</p>

Tube to Welded Systems

<p>Tube Socket Weld Union</p>  <p>TSWU 30</p>	<p>Tube Socket Weld Elbow</p>  <p>TSWE 30</p>	<p>Male Pipe Weld Connector</p>  <p>MPWC 31</p>	<p>Male Pipe Weld Elbow</p>  <p>MPWE 31</p>
---	---	---	--

Unilok Tube Fittings Selection Guide

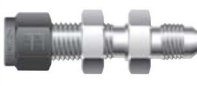

Unilok to 37° Flare (AN)

AN Union 	AN Bulkhead Union 	Female AN Adapter 	AN Adapter 
ANU 39	ANBU 39	ANF 40	ANA 40





Tube to O-Ring Seal & Tube to SAE / MS

O-Ring Seal Male Connector 	O-Ring Seal Straight Connector 	Male Connector to Straight Thread Boss 	Male Elbow to Straight Thread Boss 
OMC 42	OSC 42	MCST 43	MEST 44
45° Male Elbow to Straight Thread Boss 	Male Branch Tee to Straight Thread Boss 	Male Run Tee to Straight Thread Boss 	Male Adapter to Straight Thread Boss 
M45EST 44	MBTST 45	MRTST 45	MAST 46

Cap and Plug

Cap 
CP 47
Plug 
P 47

Components

Nut 	Ferrule 	Knurled Nut 	Bulkhead Locknut 	Tube Insert 
N 48	F 48	KN 49	BN 49	TI 49

Unilok Tube Fittings

DESIGN

Unilok tube fittings are designed and manufactured to provide a reliable, leak-proof connection in instrumentation and process tubing systems. **Unilok** tube fittings consist of three precisely machined components:

- 1) Body
- 2) Ferrule
- 3) Nut

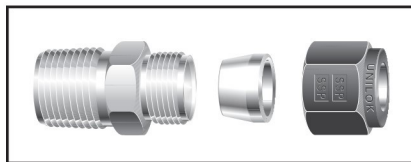

The single ferrule design, with the spring-like action of the ferrule during make-up, compensates for the variations in tubing materials, hardness and thickness of the tube wall to provide leak-tight connections in an extensive range of applications.

Additionally, in fulfillment of the design criteria, all Unilok components are manufactured with extremely tight tolerances and superior surface finishes under rigorous quality control standards to assure the optimum performance of each component part.

OPERATION

Through the critical interaction of the precisely machined fitting components with the process tube, a leak-tight seal is achieved. The simple geometric rotation of the **Unilok** nut provides the axial thrust necessary to coin the ferrule to the outside diameter of the tube. To eliminate any potential stress on an existing system, the tube fittings have been designed to not transmit installation torque from the tube fittings to the tubing.

During the rotary movement of the nut, the internal surface of the nut meets with the rear surface of the ferrule to axially move the ferrule forward into the angular section of the fitting body. The leading edge of the ferrule is directed into the tube to begin the required “bowing” action of the ferrule.

Subsequently, the leading edge of the ferrule “locks” on the outside diameter of the tube to complete the sealing action and secure the tube within the fitting.

The resulting “spring-like action” of the ferrule is designed to help compensate for exposure to system variables such as vibration, pressure pulsation and thermal expansion/contraction.

QUALITY

SSP’s Quality System has been certified to conform to the **ISO 9001:2000 Quality Standard**. Achievement of this prestigious status further confirms SSP’s continuing commitment to quality which is reflected throughout the company in its personnel, policies, equipment, products and service. In addition, all **Unilok** tube fittings are manufactured to the technical design specifications and rigid quality control standards of the SSP Instrumentation Division.

Statistical Process Control techniques are employed within the manufacturing process to



supply timely, meaningful feedback to the production team. Continual process monitoring and equipment control provide the necessary manufacturing quality for **Unilok** instrumentation grade tube fittings.

PACKAGING

Unilok tube fittings are individually bagged to assure the highest levels of quality, safety and cleanliness. The protective bags eliminate contamination (tubing burrs, dirt, etc.) from entering the fitting prior to its use, and help to retain the integrity of the factory assembled body, nut, and ferrule. As long as a **Unilok** tube fitting is in its original protective bag, it is identified as factory new, completely assembled and ready for installation.



The individually bagged **Unilok** tube fittings are packaged in convenient, small-lot quantities for easy procurement and handling.

Additionally, for efficient product identification and storage, the boxes are color-coded to the tube fittings’ material of construction and have pictorial labels which include the part number, product description and box quantity.

Unilok Tube Fittings

MATERIALS

316 STAINLESS STEEL

Unilok straight configuration tube fittings are machined from tube 316 stainless steel cold-finished bar stock in accordance with ASTM A-276 and ASTM A-479. Shaped bodies are machined from close-grained 316 stainless steel forgings in accordance with ASTM A-182. All 316 stainless steel **Unilok** components are heat code traceable with certified material test reports (CMTRs) available.

BRASS

Unilok straight configuration tube fittings are machined from CA360 and CA345 premium brass bar stock in accordance with ASTM B-16 and ASTM B-453. Shaped bodies are machined from precision forgings of CA-377 brass in accordance with ASTM B-124.

PRESSURE RATINGS.

Generally, **Unilok** tube fittings are rated for pressures equal to the maximum allowable working pressures of the tubing recommended for use with the fittings. However, it is important to note that many specially designed fittings, bored-through fittings and fittings having AN, O-Seal and SAE/MS integral ends may have lower pressure ratings than that of the tubing. (See SSP's **Selection Guide for Instrumentation Fittings and Tubing** on pages 50-53 or contact your local Authorized Distributor for more information regarding tubing and fitting pressure ratings.)

TEMPERATURE FACTORS

Unilok tube fittings function reliably in applications ranging from cryogenic temperatures to high temperature bake out with the tube fitting material as the limiting factor. It is important to note that elevated temperatures will reduce the maximum working pressure capability of the tubing system. (For more information regarding the effects of temperature on tubing pressure ratings, refer to Table 5 regarding temperature stress factors in SSP's **Selection Guide for Instrumentation Fittings and Tubing** on pages 50-53.)

GAGEABILITY

Unilok tube fittings are designed, manufactured and quality controlled to be *gageable* for sufficient pull-up during initial installation. See page 9 for additional information.

INTERCHANGEABILITY

Unilok tube fittings are designed, manufactured and quality controlled to be totally "interchangeable" with the Parker CPI™ brand of tube fittings. Component by component examination plainly shows the two brands as completely "component-intermixable." The precision manufacturing of both products to stringent tolerances under rigid quality control procedures ensures the safety, performance and reliability of service whenever **Unilok** and Parker CPI component parts are mixed and used in accordance with published installation and service recommendations.

Additionally, **Unilok** tube fittings are considered able to be "functionally interchangeable" with the Swagelok® brand of tube fitting. "Functionally interchangeable" allows for the use of a **Unilok** nut and/or ferrule with a Swagelok body, or a Swagelok nut and/or ferrule system with a **Unilok** body. The exceptional quality characteristics of both product lines assure complete product performance whenever the two brands are "functionally interchanged."

LIFETIME WARRANTY

Unilok tube fittings are covered by a published Lifetime Warranty as printed on page 54.

TUBE SELECTION

Careful selection and specification of tubing is essential to the performance of a tubing system. When choosing the appropriate tubing material, size and wall thickness, consideration must be given to the system's environment, pressures, temperatures and flows. (For more information on tube selection, please refer to SSP's **Selection Guide for Instrumentation Fittings and Tubing** on pages 50-53.)

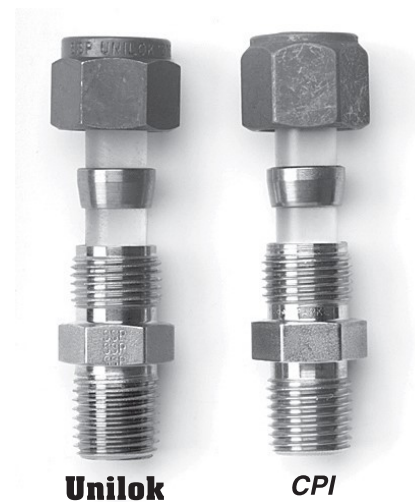

Unilok Installation Instructions

INITIAL INSTALLATION

1. **Unilok** tube fittings come individually bagged and completely assembled for immediate use. There is no need for disassembly prior to use. Simply remove the tube fitting from its bag, insert the tube* until it bottoms in the **Unilok** tube fitting body and then hand tighten the **Unilok** nut. (See Figure #1.)

Figure #1



*Tubing ends should be cut as straight as possible with all O.D. and I.D. burrs removed. Use of a tubing cutter or guide blocks with a hacksaw is recommended.

*NOTE: For extreme system applications using high pressures or requiring an extra factor of safety, it may be desirable to use a "common makeup starting point" to alleviate the inherent variations in tubing diameters. Installation should begin from a "snug" position, which is achieved by wrench tightening the **Unilok** nut until the inserted tubing will not move freely by hand (approximately 1/8 turn). From this new "snug" starting point, continue with the recommended installation instructions.*

2. While holding the fitting body stable with a back-up wrench, scribe the nut for a reference point and wrench tighten the nut 1-1/4 turns for sizes 1/4" - 1" and 3/4 turn for sizes 1/16"-3/16". (See Figures #2 and #3.)

Figure #2

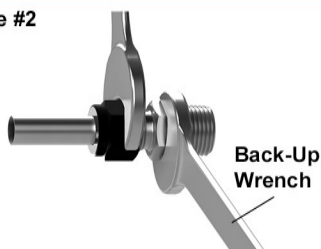
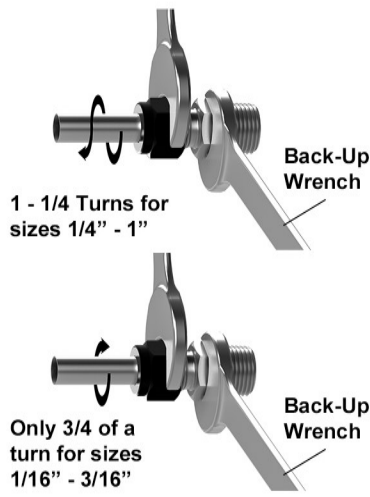

Figure #3



*Note: For all sizes, tighten plugs (P), machined ferrule end of port connector (PC) and the **Unilok** end of the Female AN Adapter (ANF) only 1/4 of a turn.*

REASSEMBLY INSTRUCTIONS

1. To reassemble a **Unilok** tube fitting connection, simply insert the tubing with the previously swaged ferrule and **Unilok** nut into the fitting body until the ferrule seats within the fitting body, and then tighten the nut by hand. (See Figure #4.)

Figure #4

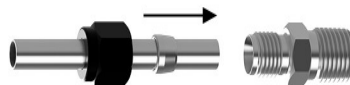

*NOTE: By following proper reassembly procedures, **Unilok** tube fitting connections may be disconnected and reconnected repeatedly.*

2. While holding the fitting body stable with a back-up wrench, use a wrench to rotate the **Unilok** nut to the fitting's original installation position (approximately 1/4 turn from the hand-tight, snug position) then continue to tighten the **Unilok** nut slightly. (See Figure #5.)

Figure #5

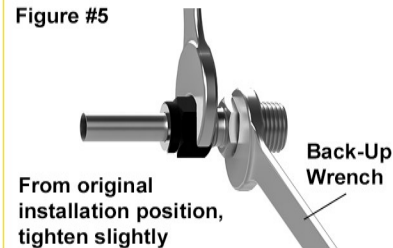

COMPONENT ASSEMBLY

Should individual component assembly of a **Unilok** tube fitting ever be required, careful attention must be given to the proper sequence and direction of the **Unilok** components. (See Figure #6.)

Figure #6

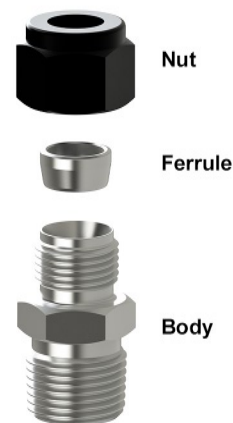

Pre-setting Tool/Gap Gage

The **Unilok** pre-setting tool is used to pre-set the ferrule on the tubing for subsequent installation in a fitting body. The pre-setting tool can be especially helpful when an installation must be made in a tight space or hard-to-work area. The pre-setting tool allows the major portion of the installation work to occur in a more favorable work setting with only the completion of the installation in the hard-to-work area.

PRE-SETTING INSTRUCTIONS

1. Secure the pre-setting tool in a vice.
2. Remove the protective nut, and assemble the **Unilok** nut and ferrule loosely to the pre-setting tool. Insert the tubing through the nut and ferrule until it bottoms in the pre-setting tool, and then follow the standard **Unilok** tube fitting installation instructions from page 9. (See Figures #7A and #7B.)

Figure #7a

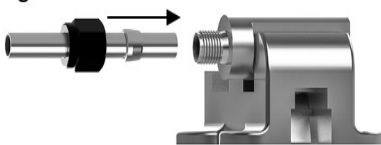
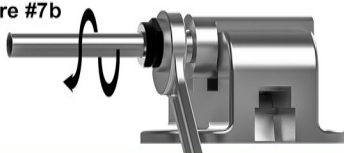
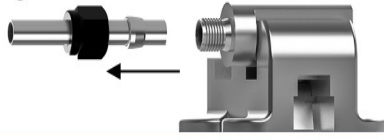

Figure #7b



3. Loosen the nut and remove the tubing with the pre-set **Unilok** ferrule and nut from the pre-setting tool. (See Figure #8.) Return the protective nut to the pre-setting tool.

Figure #8



4. Installation of the tubing, with the pre-set **Unilok** ferrule and nut in the appropriate fitting body, can now be made by following the standard reassembly instructions from page 9. (See Figures #9A and #9B.)

Figure #9a



Figure #9b

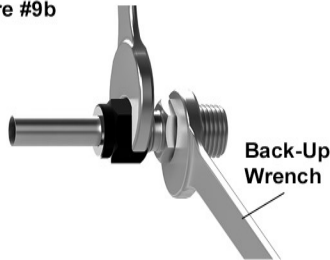

NOTE: To extend the life of a pre-setting tool, lubricate the tool with a lubricant compatible with the system's tubing material, environment and media. Also, at times, an oversized or very soft tubing may tend to stick in the pre-setting tool after make up. To remove the tubing, gently rock the tube back and forth. Never turn the tube with pliers or another tool, as such action may damage the sealing surfaces.

GAGEABILITY

Each **Unilok** tube fitting component is manufactured with utmost precision to provide the optimum performance interaction of the components during assembly. By maintaining such stringent manufacturing tolerances, **Unilok** tube fittings are considered **gageable** for sufficient pull-up during initial installation. The

Unilok "Gap Gages" are designed to identify for the installer or inspector, prior to pressurizing a system, that sufficient tightening of the tube fitting has occurred. **Gageability** provides additional reliability for proper installation and ultimate tube fitting safety and performance.

UNILOK GAP GAGE INSTRUCTIONS

1. Follow proper installation instructions (as supplied with the fittings, or published in the **Unilok** catalog).
2. After completion of the installation instructions and prior to pressuring the system, choose the proper size Gap Gage and try to insert it between the fitting's nut and body hex. (See Figure #10.)

Figure #10

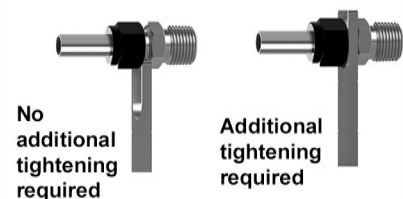

3. If the Gap Gage will not enter between the fitting's nut and body hex, no additional tightening is required.
4. If the Gap Gage will enter between the fitting's nut and body hex, additional tightening is required.

NOTE: Parker CPI Inspection Gauges may also be utilized effectively with Unilok tube fittings.

ORDERING INFORMATION

To order **Unilok** pre-setting tools and gap gages, contact your authorized SSP Instrumentation distributor.

Tube to Male Pipe

MC

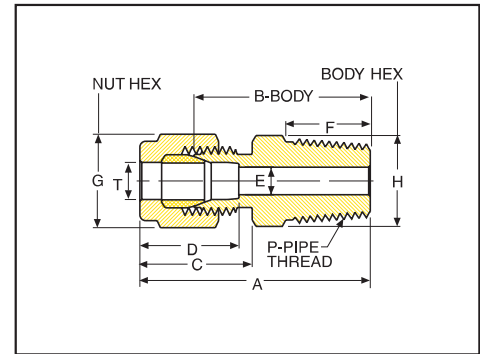

Male Connector

Unilok Part #	T Tube O.D.	P-NPT Male Pipe Size	A	B	C	D	E Minimum Opening	F Min.	G	H
U1MC1	1/16	1/16	0.94	0.79	0.43	0.34	0.05	0.38	5/16	5/16
U1MC2	1/16	1/8	1.03	0.88	0.43	0.34	0.05	0.38	5/16	7/16
U1MC4	1/16	1/4	1.22	1.07	0.43	0.34	0.05	0.56	5/16	9/16
U2MC1	1/8	1/16	1.17	0.91	0.60	0.50	0.09	0.38	7/16	7/16
U2MC2	1/8	1/8	1.20	0.94	0.60	0.50	0.09	0.38	7/16	7/16
U2MC4	1/8	1/4	1.40	1.14	0.60	0.50	0.09	0.56	7/16	9/16
U2MC6	1/8	3/8	1.41	1.15	0.60	0.50	0.09	0.56	7/16	11/16
U2MC8	1/8	1/2	1.66	1.40	0.60	0.50	0.09	0.75	7/16	7/8
U3MC2	3/16	1/8	1.23	0.97	0.63	0.54	0.12	0.38	1/2	7/16
U3MC4	3/16	1/4	1.43	1.17	0.63	0.54	0.12	0.56	1/2	9/16
U4MC1	1/4	1/16	1.29	1.00	0.70	0.60	0.11	0.38	9/16	1/2
U4MC2	1/4	1/8	1.29	1.00	0.70	0.60	0.19	0.38	9/16	1/2
U4MC4	1/4	1/4	1.49	1.20	0.70	0.60	0.19	0.56	9/16	9/16
U4MC6	1/4	3/8	1.51	1.22	0.70	0.60	0.19	0.56	9/16	11/16
U4MC8	1/4	1/2	1.76	1.47	0.70	0.60	0.19	0.75	9/16	7/8
U4MC12	1/4	3/4	1.82	1.53	0.70	0.60	0.19	0.75	9/16	11/16
U5MC2	5/16	1/8	1.34	1.05	0.73	0.64	0.19	0.38	5/8	9/16
U5MC4	5/16	1/4	1.52	1.23	0.73	0.64	0.25	0.56	5/8	9/16
U5MC6	5/16	3/8	1.54	1.25	0.73	0.64	0.25	0.56	5/8	11/16
U6MC2	3/8	1/8	1.39	1.10	0.76	0.66	0.19	0.38	11/16	5/8
U6MC4	3/8	1/4	1.57	1.28	0.76	0.66	0.28	0.56	11/16	5/8
U6MC6	3/8	3/8	1.57	1.28	0.76	0.66	0.28	0.56	11/16	1-1/16
U6MC8	3/8	1/2	1.82	1.53	0.76	0.66	0.28	0.75	11/16	7/8
U6MC12	3/8	3/4	1.88	1.59	0.76	0.66	0.28	0.75	11/16	11/16
U8MC2	1/2	1/8	1.53	1.13	0.86	0.90	0.19	0.38	7/8	13/16
U8MC4	1/2	1/4	1.71	1.31	0.86	0.90	0.28	0.56	7/8	13/16
U8MC6	1/2	3/8	1.71	1.31	0.86	0.90	0.38	0.56	7/8	13/16
U8MC8	1/2	1/2	1.93	1.53	0.86	0.90	0.41	0.75	7/8	7/8
U8MC12	1/2	3/4	1.99	1.59	0.86	0.90	0.41	0.75	7/8	1-1/16
U8MC16	1/2	1	2.25	1.85	0.86	0.90	0.41	0.94	7/8	1-3/8
U10MC6	5/8	3/8	1.74	1.34	0.86	0.96	0.38	0.56	1	15/16
U10MC8	5/8	1/2	1.93	1.53	0.86	0.96	0.47	0.75	1	15/16
U10MC12	5/8	3/4	1.99	1.59	0.86	0.96	0.50	0.75	1	1-1/16
U12MC8	3/4	1/2	1.99	1.59	0.86	0.96	0.47	0.75	1-1/8	1-1/16
U12MC12	3/4	3/4	1.99	1.59	0.86	0.96	0.62	0.75	1-1/8	1-1/16
U12MC16	3/4	1	2.25	1.85	0.86	0.96	0.62	0.94	1-1/8	1-3/8
U14MC12	7/8	3/4	1.99	1.59	0.86	1.02	0.62	0.75	1-1/4	1-3/16
U14MC16	7/8	1	2.25	1.85	0.86	1.02	0.72	0.94	1-1/4	1-3/8
U16MC8	1	1/2	2.26	1.78	1.04	1.23	0.47	0.75	1-1/2	1-3/8
U16MC12	1	3/4	2.26	1.78	1.04	1.23	0.62	0.75	1-1/2	1-3/8
U16MC16	1	1	2.45	1.97	1.04	1.23	0.88	0.94	1-1/2	1-3/8

Finger-tight assembly dimensions (shown in inches) are for reference only and subject to change.

When ordering, specify material designator with part number (see page 3 for complete ordering information).

Tube to Male Pipe

MCRS

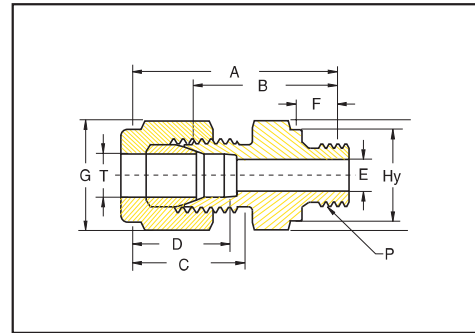
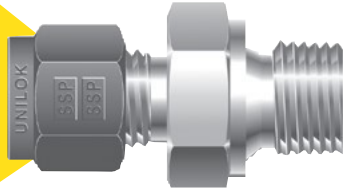

Male Connector - ISO Parallel

Unilok Part#	T Tube O.D.	P ISO Male Pipe	A	F	C	D	E	H Body Hex	Hy	G Nut Hex	B Body
U2MCRS2	1/8	1/8	1.18	0.28	0.60	0.50	0.09	9/16	0.54	7/16	0.92
U2MCRS4	1/8	1/4	1.39	0.44	0.60	0.50	0.09	3/4	0.71	7/16	1.13
U2MCRS6	1/8	3/8	1.43	0.44	0.60	0.50	0.09	7/8	0.86	7/16	1.17
U4MCRS2	1/4	1/8	1.27	0.28	0.70	0.60	0.16	9/16	0.54	9/16	0.98
U4MCRS4	1/4	1/4	1.48	0.44	0.70	0.60	0.19	3/4	0.71	9/16	1.19
U4MCRS6	1/4	3/8	1.53	0.44	0.70	0.60	0.19	7/8	0.86	9/16	1.24
U4MCRS8	1/4	1/2	1.76	0.56	0.70	0.60	0.19	1-1/16	1.02	9/16	1.47
U6MCRS4	3/8	1/4	1.54	0.44	0.76	0.66	0.23	3/4	0.71	11/16	1.25
U6MCRS6	3/8	3/8	1.59	0.44	0.76	0.66	0.28	7/8	0.86	11/16	1.30
U6MCRS8	3/8	1/2	1.82	0.56	0.76	0.66	0.28	1-1/16	1.02	11/16	1.53
U8MCRS4	1/2	1/4	1.68	0.44	0.86	0.90	0.23	13/16	0.71	7/8	1.28
U8MCRS6	1/2	3/8	1.70	0.44	0.86	0.90	0.31	7/8	0.86	7/8	1.30
U8MCRS8	1/2	1/2	1.93	0.56	0.86	0.90	0.41	1-1/16	1.02	7/8	1.53
U12MCRS8	3/4	1/2	1.93	0.56	0.86	0.96	0.47	1-1/16	1.02	1-1/8	1.53
U12MCRS12	3/4	3/4	2.08	0.62	0.86	0.96	0.62	1-5/16	1.26	1-1/8	1.68
U16MCRS8	1	1/2	2.20	0.56	1.04	1.23	0.47	1-3/8	1.02	1-1/2	1.72
U16MCRS16	1	1	2.36	0.72	1.04	1.23	0.78	1-5/8	1.54	1-1/2	1.88

NOTE: RS threaded fittings conform to ISO (International Standards Organization) standards 228/1. The standard gasket for RS fittings is a composite gasket. This gasket features a 300 series stainless steel outer ring with a Buna inner ring bonded to it.

Unilok tube fittings are designed and manufactured to provide safe, reliable leak free tubing connections.

Tube to Male Pipe

MCRT

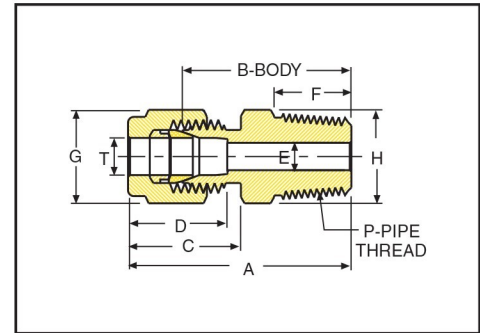
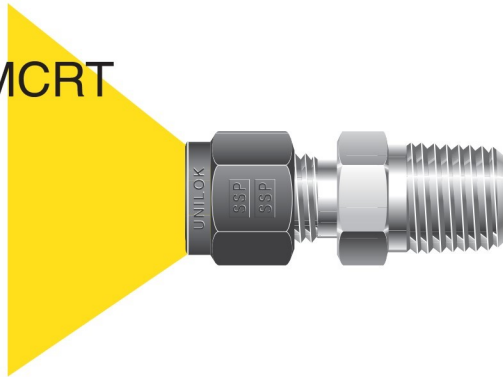

Male Connector - ISO Tapered

Unilok Part#	T Tube O.D.	P ISO Male Pipe	A	F	C	D	E Min. Opening	H Hex Flat	G Hex Flat	B Body
U2MCRT2	1/8	1/8	1.20	0.38	0.60	0.50	0.09	7/16	7/16	0.94
U2MCRT4	1/8	1/4	1.40	0.56	0.60	0.50	0.09	9/16	7/16	1.14
U4MCRT2	1/4	1/8	1.29	0.38	0.70	0.60	0.19	1/2	9/16	1.00
U4MCRT4	1/4	1/4	1.49	0.56	0.70	0.60	0.19	9/16	9/16	1.20
U4MCRT6	1/4	3/8	1.51	0.56	0.70	0.60	0.19	11/16	9/16	1.22
U4MCRT8	1/4	1/2	1.76	0.75	0.70	0.60	0.19	7/8	9/16	1.47
U5MCRT2	5/16	1/8	1.34	0.38	0.73	0.64	0.19	9/16	5/8	1.05
U5MCRT4	5/16	1/4	1.52	0.56	0.73	0.64	0.25	9/16	5/8	1.23
U6MCRT2	3/8	1/8	1.39	0.38	0.76	0.66	0.19	5/8	11/16	1.10
U6MCRT4	3/8	1/4	1.57	0.56	0.76	0.66	0.28	5/8	11/16	1.28
U6MCRT6	3/8	3/8	1.57	0.56	0.76	0.66	0.28	11/16	11/16	1.28
U6MCRT8	3/8	1/2	1.82	0.75	0.76	0.66	0.28	7/8	11/16	1.53
U8MCRT4	1/2	1/4	1.71	0.56	0.86	0.90	0.28	13/16	7/8	1.31
U8MCRT6	1/2	3/8	1.71	0.56	0.86	0.90	0.38	13/16	7/8	1.31
U8MCRT8	1/2	1/2	1.93	0.75	0.86	0.90	0.41	7/8	7/8	1.53
U8MCRT12	1/2	3/4	1.99	0.75	0.86	0.90	0.41	1-1/16	7/8	1.59
U12MCRT12	3/4	3/4	1.99	0.75	0.86	0.96	0.62	1-1/16	1-1/8	1.59
U16MCRT16	1	1	2.45	0.94	1.04	1.23	0.88	1-3/8	1-1/2	1.97

NOTE: RT threaded fittings conform to ISO (International Standards Organization) standards 7/1.

Tube to Male Pipe

MCBT

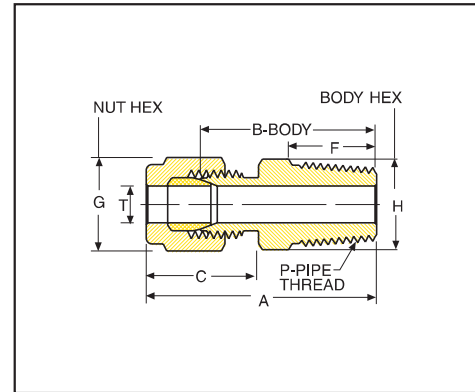

Male Connector - Bored Through

Unilok Part #	T Tube O.D.	P-NPT Male Pipe Size	A	B	C	F Min.	G	H
U1MCBT1	1/16	1/16	0.98	0.79	0.47	0.38	5/16	5/16
U1MCBT2	1/16	1/8	1.07	0.88	0.47	0.38	5/16	7/16
U2MCBT1	1/8	1/16	1.18	0.91	0.61	0.38	7/16	7/16
U2MCBT2	1/8	1/8	1.21	0.94	0.61	0.38	7/16	7/16
U2MCBT4	1/8	1/4	1.41	1.14	0.61	0.56	7/16	9/16
U3MCBT2	3/16	1/8	1.25	0.97	0.65	0.38	1/2	7/16
U3MCBT4	3/16	1/4	1.45	1.17	0.65	0.56	1/2	9/16
U4MCBT2	1/4	1/8	1.29	1.00	0.70	0.38	9/16	1/2
U4MCBT4	1/4	1/4	1.49	1.20	0.70	0.56	9/16	9/16
U4MCBT6	1/4	3/8	1.51	1.22	0.70	0.56	9/16	11/16
U4MCBT8	1/4	1/2	1.76	1.47	0.70	0.75	9/16	7/8
U5MCBT4	5/16	1/4	1.54	1.23	0.75	0.56	5/8	9/16
U6MCBT4	3/8	1/4	1.59	1.28	0.78	0.56	11/16	5/8
U6MCBT6	3/8	3/8	1.59	1.28	0.78	0.56	11/16	11/16
U6MCBT8	3/8	1/2	1.84	1.53	0.78	0.75	11/16	7/8
U8MCBT8	1/2	1/2	1.97	1.53	0.90	0.75	7/8	7/8
U10MCBT12	5/8	3/4	2.01	1.59	0.88	0.75	1	1-1/16
U12MCBT12	3/4	3/4	2.01	1.59	0.88	0.75	1-1/8	1-1/16
U16MCBT16	1	1	2.46	1.97	1.05	0.94	1-1/2	1-3/8

Thermocouple Connector

To accommodate thermocouples and other sensing probes, the MCBT series of fittings has been “bored through” to allow the thermocouple or sensor to extend beyond the end of the fitting’s NPT thread.

Note: Pressure Ratings of “bored through” tube fittings are reduced.

For additional information on a specific fitting’s rating, contact the local distributor.

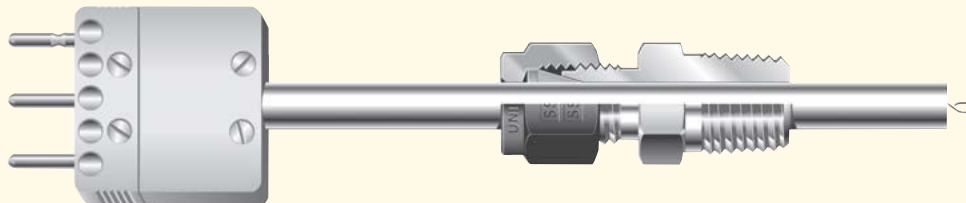

Finger-tight assembly dimensions (shown in inches) are for reference only and subject to change.

When ordering, specify material designator with part number (see page 3 for complete ordering information).

Tube to Male Pipe

BMC

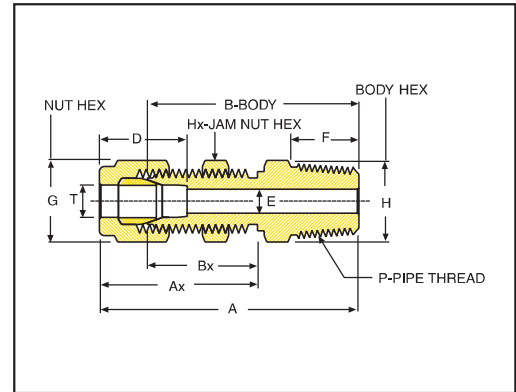
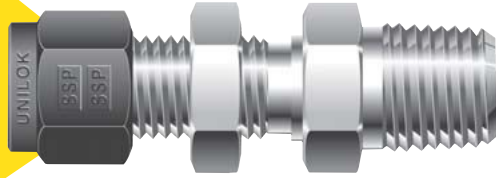

Bulkhead Male Connector

Unilok Part #	T tube O.D.	P-NPT Male Pipe Size	A	Ax	B	Bx	D	E Minimum Opening	F Min.	G	H	Hx	Maximum Panel Thickness	Panel Hole Drill Size
U2BMC2	1/8	1/8	1.83	1.23	1.57	0.97	0.50	0.09	0.38	7/16	1/2	1/2	0.50	21/64
U4BMC2	1/4	1/8	1.95	1.32	1.66	1.03	0.60	0.17	0.38	9/16	5/8	5/8	0.40	29/64
U4BMC4	1/4	1/4	2.10	1.32	1.81	1.03	0.60	0.19	0.56	9/16	5/8	5/8	0.40	29/64
U6BMC4	3/8	1/4	2.26	1.45	1.97	1.16	0.66	0.28	0.56	11/16	3/4	3/4	0.44	37/64
U8BMC6	1/2	3/8	2.49	1.65	2.09	1.25	0.90	0.37	0.56	7/8	15/16	15/16	0.50	49/64
U8BMC8	1/2	1/2	2.71	1.65	2.31	1.25	0.90	0.41	0.75	7/8	15/16	15/16	0.50	49/64

M45E

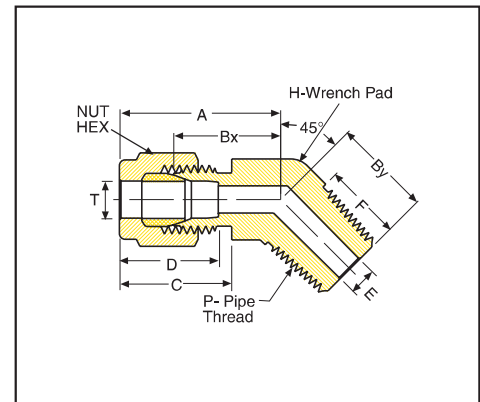

45° Male Elbow

Unilok Part #	T Tube O.D.	P-NPT Male Pipe Size	A	Bx	By	C	U	E Minimum Opening	F Min.	G	H
U4M45E2	1/4	1/8	0.97	0.68	0.65	0.70	0.60	0.17	0.38	9/16	9/16
U4M45E4	1/4	1/4	0.97	0.68	0.83	0.70	0.60	0.19	0.56	9/16	9/16
U6M45E2	3/8	1/8	1.10	0.81	0.72	0.76	0.66	0.19	0.38	11/16	5/8
U6M45E4	3/8	1/4	1.10	0.81	0.90	0.76	0.66	0.28	0.56	11/16	5/8
U6M45E6	3/8	3/8	1.15	0.86	0.95	0.76	0.66	0.28	0.56	11/16	3/4
U8M45E6	1/2	3/8	1.26	0.86	0.95	0.86	0.90	0.38	0.56	7/8	13/16

Finger-tight assembly dimensions (shown in inches) are for reference only and subject to change.

When ordering, specify material designator with part number (see page 3 for complete ordering information).

Tube to Male Pipe

ME

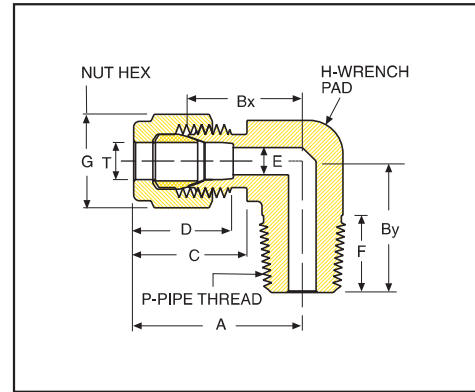
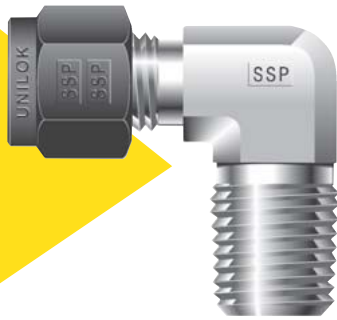

Male Elbow

Unilok Part #	T Tube O.D.	P-NPT Male Pipe Size	A	Bx	By	C	U	E Minimum Opening	F Min.	G	H
U1ME1	1/16	1/16	0.75	0.60	0.70	0.43	0.34	0.05	0.38	5/16	7/16
U1ME2	1/16	1/8	0.75	0.60	0.70	0.43	0.34	0.05	0.38	5/16	1/2
U2ME1	1/8	1/16	0.93	0.67	0.70	0.60	0.50	0.09	0.38	7/16	7/16
U2ME2	1/8	1/8	0.93	0.67	0.70	0.60	0.50	0.09	0.38	7/16	7/16
U2ME4	1/8	1/4	0.97	0.71	0.92	0.60	0.50	0.09	0.56	7/16	1/2
U3ME2	3/16	1/8	1.00	0.74	0.74	0.63	0.54	0.12	0.38	1/2	1/2
U3ME4	3/16	1/4	1.00	0.74	0.92	0.63	0.54	0.12	0.56	1/2	1/2
U4ME2	1/4	1/8	1.06	0.77	0.74	0.70	0.60	0.17	0.38	9/16	1/2
U4ME4	1/4	1/4	1.06	0.77	0.92	0.70	0.60	0.19	0.56	9/16	1/2
U4ME6	1/4	3/8	1.17	0.88	1.03	0.70	0.60	0.19	0.56	9/16	11/16
U4ME8	1/4	1/2	1.25	0.96	1.30	0.70	0.60	0.19	0.75	9/16	7/8
U5ME2	5/16	1/8	1.13	0.84	0.78	0.73	0.64	0.19	0.38	5/8	9/16
U5ME4	5/16	1/4	1.13	0.84	0.96	0.73	0.64	0.25	0.56	5/8	9/16
U5ME6	5/16	3/8	1.20	0.91	1.03	0.73	0.64	0.25	0.56	5/8	11/16
U6ME2	3/8	1/8	1.20	0.91	0.82	0.76	0.66	0.19	0.38	11/16	5/8
U6ME4	3/8	1/4	1.20	0.91	1.00	0.76	0.66	0.28	0.56	11/16	5/8
U6ME6	3/8	3/8	1.23	0.94	1.03	0.76	0.66	0.28	0.56	11/16	11/16
U6ME8	3/8	1/2	1.31	1.02	1.30	0.76	0.66	0.28	0.75	11/16	7/8
U6ME12	3/8	3/4	1.46	1.17	1.45	0.76	0.66	0.28	0.75	11/16	1-1/16
U8ME4	1/2	1/4	1.42	1.02	1.11	0.86	0.90	0.28	0.56	7/8	13/16
U8ME6	1/2	3/8	1.42	1.02	1.11	0.86	0.90	0.38	0.56	7/8	13/16
U8ME8	1/2	1/2	1.42	1.02	1.30	0.86	0.90	0.41	0.75	7/8	7/8
U8ME12	1/2	3/4	1.57	1.17	1.45	0.86	0.90	0.41	0.75	7/8	1-1/16
U10ME6	5/8	3/8	1.50	1.10	1.19	0.86	0.96	0.38	0.56	1	15/16
U10ME8	5/8	1/2	1.50	1.10	1.38	0.86	0.96	0.47	0.75	1	15/16
U10ME12	5/8	3/4	1.57	1.17	1.45	0.86	0.96	0.50	0.75	1	1-1/16
U12ME8	3/4	1/2	1.57	1.17	1.45	0.86	0.96	0.47	0.75	1-1/8	1-1/16
U12ME12	3/4	3/4	1.57	1.17	1.45	0.86	0.96	0.62	0.75	1-1/8	1-1/16
U14ME12	7/8	3/4	1.76	1.36	1.64	0.86	1.02	0.62	0.75	1-1/4	1-3/8
U16ME12	1	3/4	1.93	1.45	1.64	1.04	1.23	0.62	0.75	1-1/2	1-3/8
U16ME16	1	1	1.93	1.45	1.83	1.04	1.23	0.88	0.75	1-1/2	1-3/8

Finger-tight assembly dimensions (shown in inches) are for reference only and subject to change.

When ordering, specify material designator with part number (see page 3 for complete ordering information).

Tube to Male Pipe

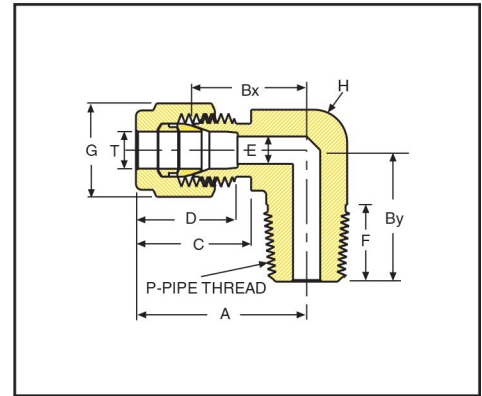
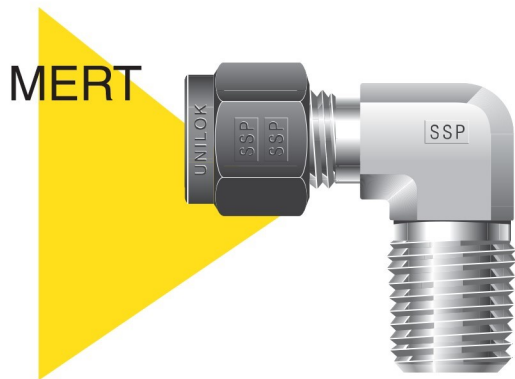

Male Elbow - ISO Tapered

Unilok Part#	T Tube O.D.	P ISO Male Pipe	A	F	C	D	E Min. Opening	H Wrench Pad	G Hex Flat	Bx	By
U2MERT2	1/8	1/8	.093	0.38	0.60	0.50	0.09	7/16	7/16	0.67	0.70
U4MERT2	1/4	1/8	1.06	0.38	0.70	0.60	0.19	1/2	9/16	0.77	0.74
U4MERT4	1/4	1/4	1.06	0.56	0.70	0.60	0.19	1/2	9/16	0.77	0.92
U4MERT6	1/4	3/8	1.17	0.56	0.70	0.60	0.19	11/16	9/16	0.88	1.03
U4MERT8	1/4	1/2	1.25	0.75	0.70	0.60	0.19	13/16	9/16	0.96	1.30
U5MERT4	5/16	1/4	1.13	0.56	0.73	0.64	0.25	9/16	5/8	0.84	0.96
U6MERT2	3/8	1/8	1.20	0.38	0.76	0.66	0.19	5/8	11/16	0.91	0.82
U6MERT4	3/8	1/4	1.20	0.56	0.76	0.66	0.28	5/8	11/16	0.91	1.00
U6MERT6	3/8	3/8	1.23	0.56	0.76	0.66	0.28	11/16	11/16	0.94	1.03
U6MERT8	3/8	1/2	1.31	0.75	0.76	0.66	0.28	13/16	11/16	1.02	1.30
U8MERT4	1/2	1/4	1.42	0.56	0.86	0.90	0.28	13/16	7/8	1.02	1.11
U8MERT6	1/2	3/8	1.42	0.56	0.86	0.90	0.38	13/16	7/8	1.02	1.11
U8MERT8	1/2	1/2	1.42	0.75	0.86	0.90	0.41	13/16	7/8	1.02	1.30

NOTE: RT threaded fittings conform to ISO (International Standards Organization) standards 7/1.

Always specify genuine Unilok tube fittings.

Tube to Male Pipe

MBT

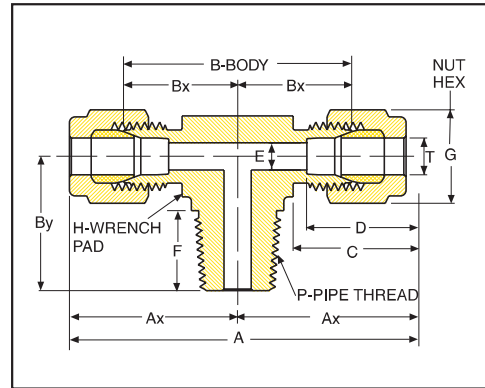
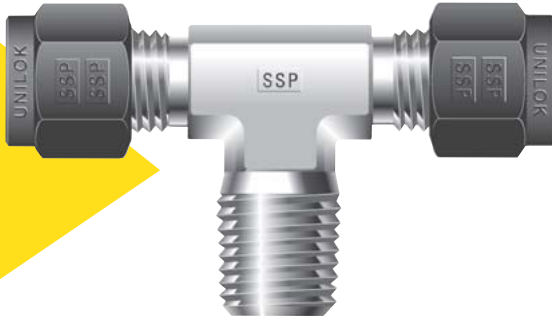

Male Branch Tee

Unilok Part #	T Tube O.D.	P-NPT Male Pipe Size	A	Ax	B	Bx	By	C	U	E Minimum Opening	F Min.	G	H
U2MBT2	1/8	1/8	1.86	0.93	1.34	0.67	0.70	0.60	0.50	0.09	0.38	7/16	7/16
U2MBT4	1/8	1/4	1.94	0.97	1.42	0.71	0.92	0.60	0.50	0.09	0.56	7/16	9/16
U3MBT2	3/16	1/8	1.92	0.96	1.40	0.70	0.70	0.63	0.54	0.12	0.38	1/2	7/16
U4MBT2	1/4	1/8	2.12	1.06	1.54	0.77	0.74	0.70	0.60	0.17	0.38	9/16	1/2
U4MBT4	1/4	1/4	2.12	1.06	1.54	0.77	0.92	0.70	0.60	0.17	0.56	9/16	9/16
U5MBT2	5/16	1/8	2.34	1.17	1.76	0.88	0.82	0.73	0.64	0.19	0.38	5/8	5/8
U6MBT4	3/8	1/4	2.40	1.20	1.82	0.91	1.00	0.76	0.66	0.28	0.56	11/16	5/8
U6MBT6	3/8	3/8	2.62	1.31	2.04	1.02	1.11	0.76	0.66	0.28	0.56	11/16	13/16
U8MBT6	1/2	3/8	2.84	1.42	2.04	1.02	1.11	0.86	0.90	0.38	0.56	7/8	13/16
U8MBT8	1/2	1/2	2.84	1.42	2.04	1.02	1.30	0.86	0.90	0.41	0.75	7/8	7/8
U10MBT8	5/8	1/2	3.06	1.53	2.26	1.13	1.41	0.86	0.96	0.47	0.75	1	1
U12MBT12	3/4	3/4	3.14	1.57	2.34	1.17	1.45	0.86	0.96	0.62	0.75	1-1/8	1-1/16

MRT

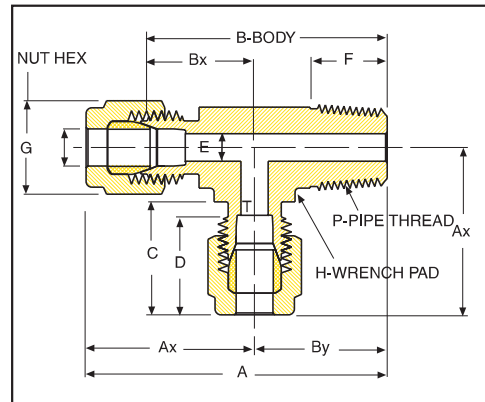
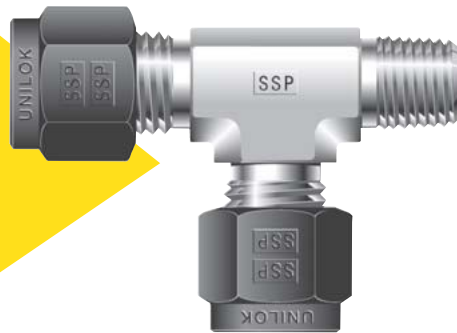

Male Run Tee

Unilok Part #	T Tube O.D.	P-NPT Male Pipe Size	A	Ax	B	Bx	By	C	D	E Minimum Opening	F Min.	G	H
U2MRT2	1/8	1/8	1.63	0.93	1.37	0.67	0.70	0.60	0.50	0.09	0.38	7/16	7/16
U2MRT4	1/8	1/4	1.89	0.97	1.63	0.71	0.92	0.60	0.50	0.09	0.56	7/16	9/16
U3MRT2	3/16	1/8	1.66	0.96	1.40	0.70	0.70	0.63	0.54	0.12	0.38	1/2	7/16
U4MRT2	1/4	1/8	1.80	1.06	1.51	0.77	0.74	0.70	0.60	0.17	0.38	9/16	1/2
U4MRT4	1/4	1/4	1.98	1.06	1.69	0.77	0.92	0.70	0.60	0.19	0.56	9/16	9/16
U5MRT2	5/16	1/8	1.99	1.17	1.70	0.88	0.82	0.73	0.64	0.19	0.38	5/8	5/8
U6MRT4	3/8	1/4	2.20	1.20	1.91	0.91	1.00	0.76	0.66	0.28	0.56	11/16	5/8
U6MRT6	3/8	3/8	2.42	1.31	2.13	1.02	1.11	0.76	0.66	0.28	0.56	11/16	13/16
U8MRT6	1/2	3/8	2.53	1.42	2.13	1.02	1.11	0.86	0.90	0.38	0.56	7/8	13/16
U8MRT8	1/2	1/2	2.72	1.42	2.32	1.02	1.30	0.86	0.90	0.41	0.75	7/8	7/8
U10MRT8	5/8	1/2	2.88	1.50	2.48	1.10	1.38	0.86	0.96	0.47	0.75	1	1
U12MRT12	3/4	3/4	3.02	1.57	2.62	1.17	1.45	0.86	0.96	0.62	0.75	1-1/8	1-1/16

Finger-tight assembly dimensions (shown in inches) are for reference only and subject to change.

When ordering, specify material designator with part number (see page 3 for complete ordering information).

Tube to Female Pipe

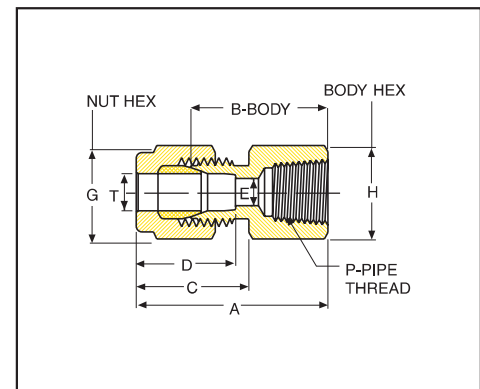
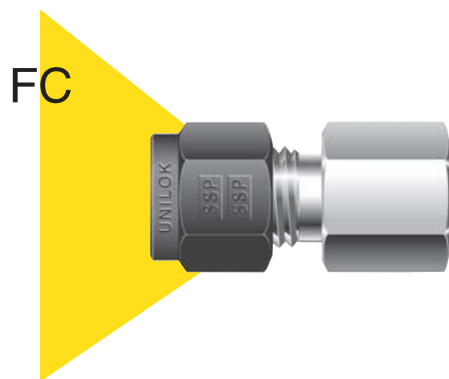

Female Connector

Unilok Part #	T Tube O.D.	P-NPT Female Pipe Size	A	B	C	D	E Minimum Opening	G	H
U1FC1	1/16	1/16	0.93	0.78	0.43	0.34	0.05	5/16	7/16
U1FC2	1/16	1/8	0.96	0.81	0.43	0.34	0.05	5/16	9/16
U2FC2	1/8	1/8	1.13	0.87	0.60	0.50	0.09	7/16	9/16
U2FC4	1/8	1/4	1.32	1.06	0.60	0.50	0.09	7/16	3/4
U3FC2	3/16	1/8	1.17	0.91	0.63	0.54	0.12	1/2	9/16
U4FC2	1/4	1/8	1.23	0.94	0.70	0.60	0.19	9/16	9/16
U4FC4	1/4	1/4	1.41	1.12	0.70	0.60	0.19	9/16	3/4
U4FC6	1/4	3/8	1.48	1.19	0.70	0.60	0.19	9/16	7/8
U4FC8	1/4	1/2	1.67	1.38	0.70	0.60	0.19	9/16	1 1/16
U5FC2	5/16	1/8	1.26	0.97	0.73	0.64	0.25	5/8	9/16
U5FC4	5/16	1/4	1.45	1.16	0.73	0.64	0.25	5/8	3/4
U6FC2	3/8	1/8	1.29	1.00	0.76	0.66	0.28	11/16	5/8
U6FC4	3/8	1/4	1.48	1.19	0.76	0.66	0.28	11/16	3/4
U6FC6	3/8	3/8	1.54	1.25	0.76	0.66	0.28	11/16	7/8
U6FC8	3/8	1/2	1.73	1.44	0.76	0.66	0.28	11/16	1-1/16
U6FC12	3/8	3/4	1.88	1.59	0.76	0.66	0.28	11/16	1-5/16
U8FC4	1/2	1/4	1.59	1.19	0.86	0.90	0.41	7/8	13/16
U8FC6	1/2	3/8	1.65	1.25	0.86	0.90	0.41	7/8	7/8
U8FC8	1/2	1/2	1.84	1.44	0.86	0.90	0.41	7/8	1-1/16
U8FC12	1/2	3/4	1.90	1.50	0.86	0.90	0.41	7/8	1-5/16
U10FC6	5/8	3/8	1.65	1.25	0.86	0.96	0.50	1	1-5/16
U10FC8	5/8	1/2	1.84	1.44	0.86	0.96	0.50	1	1-1/16
U12FC8	3/4	1/2	1.84	1.44	0.86	0.96	0.62	1-1/8	1-1/16
U12FC12	3/4	3/4	1.90	1.50	0.86	0.96	0.62	1-1/8	1-5/16
U14FC12	7/8	3/4	1.96	1.56	0.86	1.02	0.72	1-1/4	1-5/16
U16FC12	1	3/4	2.10	1.62	1.04	1.23	0.88	1-1/2	1-3/8
U16FC16	1	1	2.45	1.97	1.04	1.23	0.88	1-1/2	1-5/8

Finger-tight assembly dimensions (shown in inches) are for reference only and subject to change.

When ordering, specify material designator with part number (see page 3 for complete ordering information).

Tube to Female Pipe

BFC

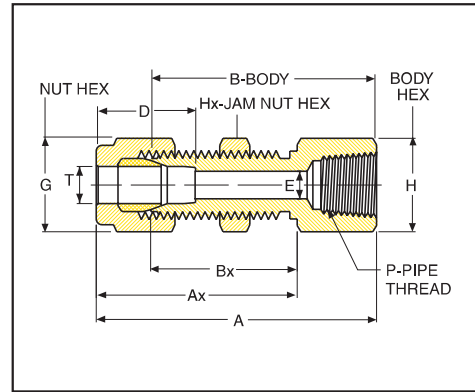
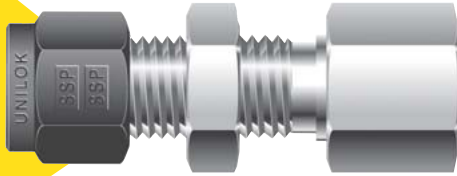

Bulkhead Female Connector

Unilok Part #	T Tube O.D.	P-NPT Female Pipe Size	A	Ax	B	Bx	D	E Minimum Opening	G	H	Hx	Maximum Panel Thickness	Panel Hole Drill Size
U2BFC2	1/8	1/8	1.76	1.23	1.50	0.97	0.50	0.09	7/16	9/16	1/2	0.50	21/64
U4BFC2	1/4	1/8	1.85	1.32	1.56	1.03	0.60	0.19	9/16	5/8	5/8	0.40	29/64
U4BFC4	1/4	1/4	2.04	1.32	1.75	1.03	0.60	0.19	9/16	3/4	5/8	0.40	29/64
U6BFC4	3/8	1/4	2.17	1.45	1.88	1.16	0.66	0.28	11/16	3/4	3/4	0.44	37/64
U8BFC6	1/2	3/8	2.43	1.65	2.03	1.25	0.90	0.41	7/8	15/16	15/16	0.50	49/64
U8BFC8	1/2	1/2	2.62	1.65	2.22	1.25	0.90	0.41	7/8	1-1/16	15/16	0.50	49/64

Unilok products are readily available from factory authorized distributors.

Finger-tight assembly dimensions (shown in inches) are for reference only and subject to change.

When ordering, specify material designator with part number (see page 3 for complete ordering information).

Tube to Female Pipe

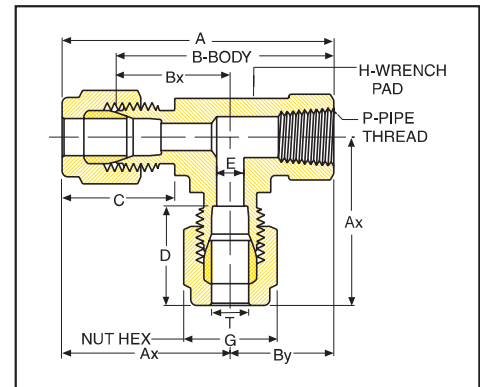
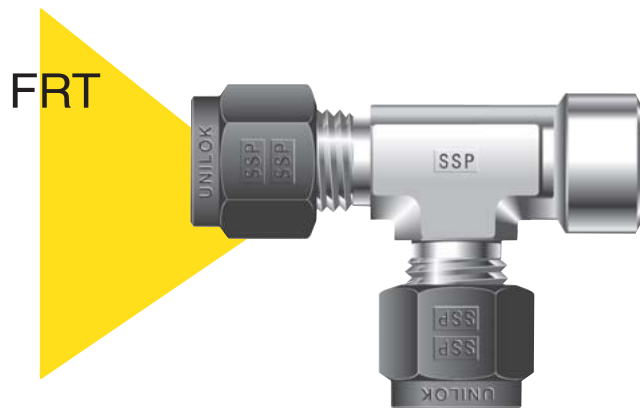

Female Run Tee

Unilok Part #	T Tube O.D.	P-NPT Female Pipe Size	A	Ax	B	Bx	By	C	D	E Minimum Opening	G	H
U2FRT2	1/8	1/8	1.72	0.97	1.46	0.71	0.75	0.60	0.50	0.09	7/16	9/16
U4FRT2	1/4	1/8	1.81	1.06	1.52	0.77	0.75	0.70	0.60	0.19	9/16	9/16
U4FRT4	1/4	1/4	2.05	1.17	1.76	0.88	0.88	0.70	0.60	0.19	9/16	3/4
U6FRT4	3/8	1/4	2.11	1.23	1.82	0.94	0.88	0.76	0.66	0.28	11/16	3/4
U8FRT6	1/2	3/8	2.30	1.42	1.90	1.02	0.88	0.86	0.90	0.41	7/8	7/8
U8FRT8	1/2	1/2	2.69	1.57	2.29	1.17	1.12	0.86	0.90	0.41	7/8	1-1/16
U12FRT12	3/4	3/4	3.01	1.76	2.61	1.36	1.25	0.86	0.96	0.62	1-1/8	1-3/8

See page 9 for the safe, simple installation instructions for Unilok tube fittings.

Tube to Female Pipe

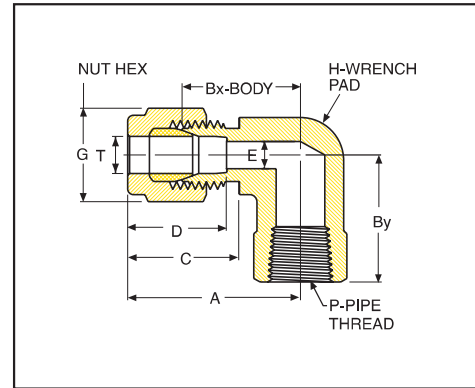
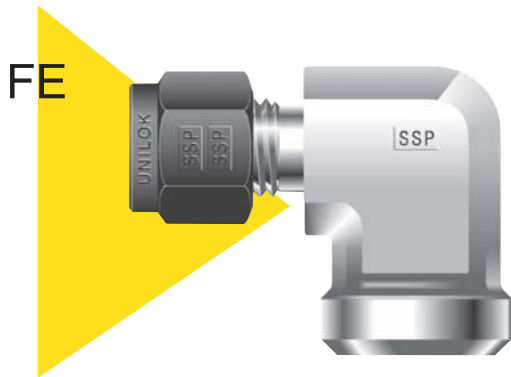

Female Elbow

Unilok Part #	T Tube O.D.	P-NPT Female Pipe Size	A	Bx	By	C	D	E Minimum Opening	G	H
U2FE2	1/8	1/8	0.97	0.71	0.75	0.60	0.50	0.09	7/16	1/2
U2FE4	1/8	1/4	1.08	0.82	0.88	0.60	0.50	0.09	7/16	11/16
U3FE2	3/16	1/8	1.00	0.74	0.75	0.63	0.54	0.12	1/2	1/2
U4FE2	1/4	1/8	1.06	0.77	0.75	0.70	0.60	0.19	9/16	1/2
U4FE4	1/4	1/4	1.17	0.88	0.88	0.70	0.60	0.19	9/16	11/16
U4FE6	1/4	3/8	1.25	0.96	0.88	0.70	0.60	0.19	9/16	7/8
U4FE8	1/4	1/2	1.36	1.07	1.12	0.70	0.60	0.19	9/16	1
U5FE2	5/16	1/8	1.13	0.84	0.75	0.73	0.64	0.25	5/8	9/16
U5FE4	5/16	1/4	1.20	0.91	0.88	0.73	0.64	0.25	5/8	11/16
U6FE2	3/8	1/8	1.20	0.91	0.75	0.76	0.66	0.28	11/16	5/8
U6FE4	3/8	1/4	1.23	0.94	0.88	0.76	0.66	0.28	11/16	11/16
U6FE6	3/8	3/8	1.31	1.02	0.88	0.76	0.66	0.28	11/16	7/8
U6FE8	3/8	1/2	1.42	1.13	1.12	0.76	0.66	0.28	11/16	1
U8FE4	1/2	1/4	1.42	1.02	0.88	0.86	0.90	0.41	7/8	13/16
U8FE6	1/2	3/8	1.42	1.02	0.88	0.86	0.90	0.41	7/8	7/8
U8FE8	1/2	1/2	1.53	1.13	1.12	0.86	0.90	0.41	7/8	1
U10FE6	5/8	3/8	1.50	1.10	0.88	0.86	0.96	0.50	1	15/16
U10FE8	5/8	1/2	1.57	1.17	1.12	0.86	0.96	0.50	1	1-1/16
U12FE8	3/4	1/2	1.57	1.17	1.12	0.86	0.96	0.62	1-1/8	1-1/16
U12FE12	3/4	3/4	1.76	1.36	1.25	0.86	0.96	0.62	1-1/8	1-3/8
U14FE12	7/8	3/4	1.76	1.36	1.25	0.86	1.02	0.72	1-1/4	1-3/8
U16FE12	1	3/4	1.93	1.45	1.25	1.04	1.23	0.88	1-1/2	1-3/8
U16FE16	1	1	2.11	1.63	1.50	1.04	1.23	0.88	1-1/2	1-5/8

Finger-tight assembly dimensions (shown in inches) are for reference only and subject to change.

When ordering, specify material designator with part number (see page 3 for complete ordering information).

Tube to Female Pipe / Tube to Tube Union

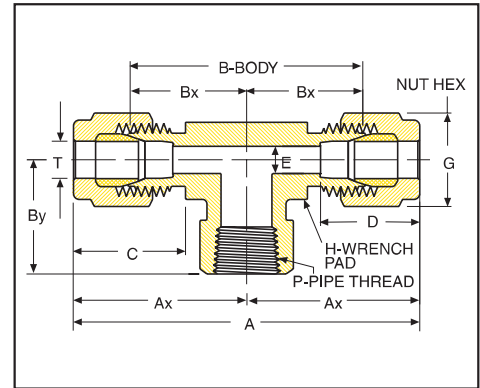
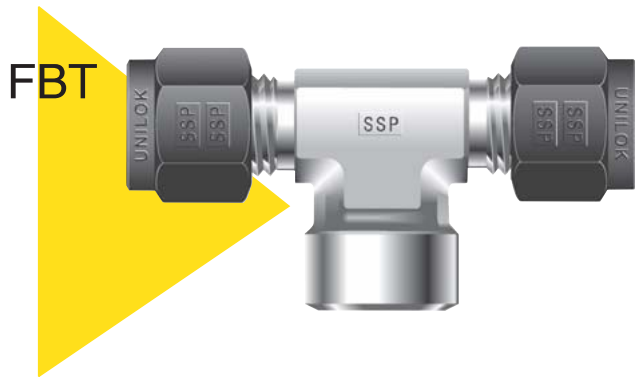

Female Branch Tee

Unilok Part #	T Tube O.D.	P-NPT Female Pipe Size	A	Ax	B	Bx	By	C	D	E Minimum Opening	G	H
U2FBT2	1/8	1/8	1.94	0.97	1.42	0.71	0.75	0.60	0.50	0.09	7/16	9/16
U4FBT2	1/4	1/8	2.12	1.06	1.54	0.77	0.75	0.70	0.60	0.19	9/16	9/16
U4FBT4	1/4	1/4	2.34	1.17	1.76	0.88	0.88	0.70	0.60	0.19	9/16	3/4
U6FBT4	3/8	1/4	2.46	1.23	1.88	0.94	0.88	0.76	0.66	0.28	11/16	3/4
U8FBT4	1/2	1/4	2.84	1.42	2.04	1.02	0.88	0.86	0.90	0.41	7/8	13/16
U8FBT6	1/2	3/8	2.84	1.42	2.04	1.02	0.88	0.86	0.90	0.41	7/8	7/8
U8FBT8	1/2	1/2	3.06	1.53	2.26	1.13	1.12	0.86	0.90	0.41	7/8	1
U10FBT8	5/8	1/2	3.06	1.53	2.26	1.13	1.12	0.86	0.96	0.50	1	1
U12FBT12	3/4	3/4	3.52	1.76	2.72	1.36	1.25	0.86	0.96	0.62	1-1/8	1-3/8
U16FBT12	1	3/4	3.86	1.93	2.90	1.45	1.25	1.04	1.23	0.88	1-1/2	1-3/8
U16FBT16	1	1	4.22	2.11	3.26	1.63	1.50	1.04	1.23	0.88	1-1/2	1-5/8

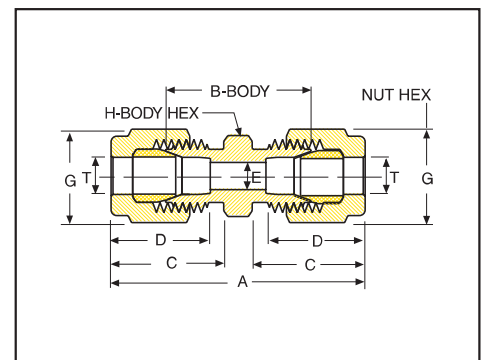

Union

Unilok Part #	T Tube O.D.	A	B	C	D	E Minimum Opening	G	H
U1U	1/16	0.99	0.69	0.43	0.34	0.05	5/16	5/16
U2U	1/8	1.40	0.88	0.60	0.50	0.09	7/16	7/16
U3U	3/16	1.47	0.95	0.63	0.54	0.12	1/2	7/16
U4U	1/4	1.61	1.03	0.70	0.60	0.19	9/16	1/2
U5U	5/16	1.69	1.11	0.73	0.64	0.25	5/8	9/16
U6U	3/8	1.77	1.19	0.76	0.66	0.28	11/16	5/8
U8U	1/2	2.02	1.22	0.86	0.90	0.41	7/8	13/16
U10U	5/8	2.05	1.25	0.86	0.96	0.50	1	15/16
U12U	3/4	2.11	1.31	0.86	0.96	0.62	1-1/8	1-1/16
U14U	7/8	2.17	1.37	0.86	1.02	0.72	1-1/4	1-3/16
U16U	1	2.55	1.59	1.04	1.23	0.88	1-1/2	1-3/8

Finger-tight assembly dimensions (shown in inches) are for reference only and subject to change.

When ordering, specify material designator with part number (see page 3 for complete ordering information).

Tube to Tube Union

BU

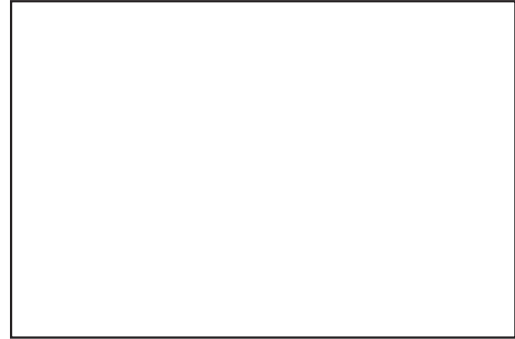

Bulkhead Union

Unilok Part #	T Tube O.D.	A	Ax	B	Bx	C	D	E Minimum Opening	G	H	Maximum Panel Thickness	Panel Hole Drill Size
U1BU	1/16	1.24	0.68	0.94	0.53	0.43	0.34	0.05	5/16	5/16	0.12	13/16
U2BU	1/8	2.02	1.23	1.50	0.97	0.60	0.50	0.09	7/16	1/2	0.50	21/64
U3BU	3/16	2.11	1.26	1.59	1.00	0.63	0.54	0.12	1/2	9/16	0.50	25/64
U4BU	1/4	2.27	1.32	1.69	1.03	0.70	0.60	0.19	9/16	5/8	0.40	29/64
U5BU	5/16	2.39	1.41	1.81	1.12	0.73	0.64	0.25	5/8	11/16	0.44	33/64
U6BU	3/8	2.45	1.45	1.87	1.16	0.76	0.66	0.28	11/16	3/4	0.44	37/64
U8BU	1/2	2.80	1.65	2.00	1.25	0.86	0.90	0.41	7/8	15/16	0.50	49/64
U10BU	5/8	2.86	1.68	2.06	1.28	0.86	0.96	0.50	1	1-1/16	0.50	57/64
U12BU	3/4	3.11	1.87	2.31	1.47	0.86	0.96	0.63	1-1/8	1-3/16	0.66	1-1/64
U16BU	1	3.77	2.26	2.81	1.78	1.04	1.23	0.88	1-1/2	1-5/8	0.75	1-21/64

BRU

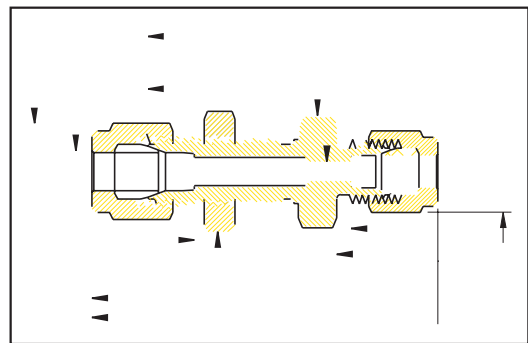
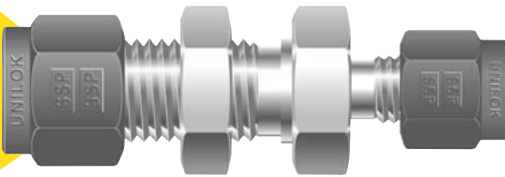

Bulkhead Reducing Union

Unilok Part #	T Tube O.D.	Tx Tube O.D.	A	Ax	B	Bx	Cx	D	Dx	E Minimum Opening	G	Gx	H	Hx	Maximum Panel Thickness	Panel Hole Drill Size
U4BRU2	1/4	1/8	2.17	1.32	1.62	1.03	.60	.60	.50	.09	9/16	7/16	5/8	5/8	.40	29/64
U6BRU4	3/8	1/4	2.39	1.44	1.81	1.16	.70	.66	.60	.19	11/16	9/16	3/4	3/4	.44	37/64
U8BRU4	1/2	1/4	2.63	1.65	1.94	1.25	.70	.90	.60	.19	7/8	9/16	15/16	15/16	.50	49/64
U8BRU6	1/2	3/8	2.68	1.65	1.99	1.25	.75	.90	.66	.19	7/8	11/16	15/16	15/16	.50	49/64

Finger-tight assembly dimensions (shown in inches) are for reference only and subject to change.

When ordering, specify material designator with part number (see page 3 for complete ordering information).